



Discover[®] SP
Microwave Synthesizer





Microwave Synthesis Made Easy

The Discover® SP is a powerful microwave synthesizer for performing a wide range of organic and inorganic synthetic chemistry. The system features a best-in-class 300 mL single-mode microwave cavity, allowing for extremely flexible reaction vessel sizes, in both pressurized and open vessel modes.

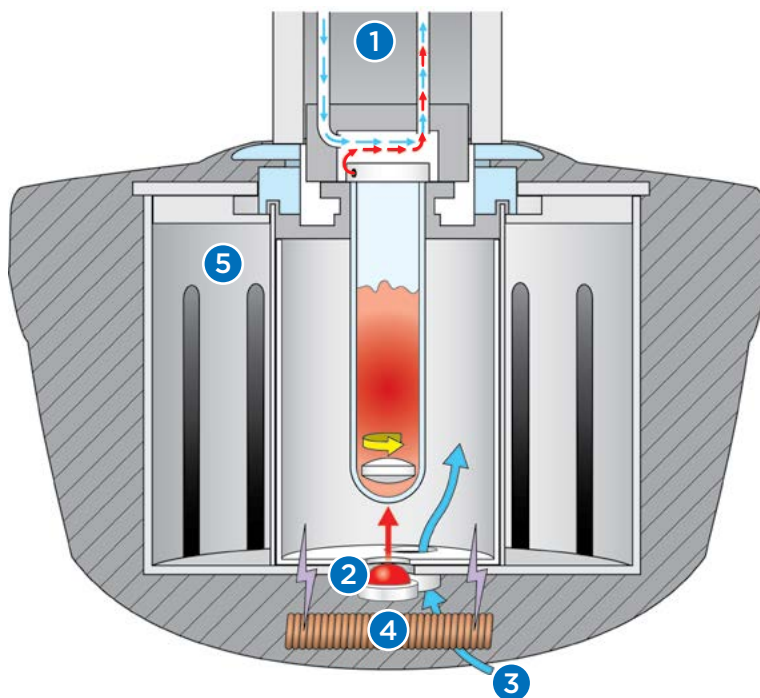

1 **Activent® Pressure Device**

Unique and patented pressure device allows for programmable reaction venting to relieve gaseous byproducts and reduce vessel failures.

2 **Volume Independent IR Temperature Sensor**

The Discover SP patented, floor-mounted IR temperature sensor is the simplest and most effective way to measure temperature in a non-invasive manner. Since the vessel temperature is measured from below, you won't have to worry about the reaction volume in your vessel as you do with other systems. Our design requires only two vessel sizes to cover the same range of working volumes as three (or even four vessels) on systems with side-mounted IR sensors.

3 **Air Cooling for Reaction Quenching**

Quickly reduce the overall reaction temperature to quench the reaction upon completion.

4 **Electromagnetic Stirring**

Ensure maximum agitation for your reaction mixture. Adjust the speed to guarantee your sample mixes each and every time.

Self-Tuning, Efficient Microwave Cavity

5 Take the guesswork out of ensuring the reaction is positioned correctly every time, no matter which vessel you use. As the reaction progresses, the microwave energy distribution adjusts automatically for changing chemical properties to optimally heat the reaction.

Reliable

The Discover SP features a robust, proven cavity for efficient heating of sealed vessels and reflux reactions. The cavity's advanced membrane design and specially formulated coating protects parts from solvents and reagents. The circular waveguide efficiently uses up to 300 W of power, prolonging the life of the magnetron.

Easiest to Clean

The Discover SP is designed with a removable spill cup, as well as a drain tray, for easy clean up. There's nothing to disassemble, just clean out the cup and the tray and you're ready to run another reaction.

Do More with Less Power

The Discover SP cavity design compensates for the changing chemical properties of the reaction and allows the optimum amount of microwave energy to reach the reaction, to ensure safe heating. This efficiency allows the system to use up to 300 W of power, more effectively than any other microwave reactor.

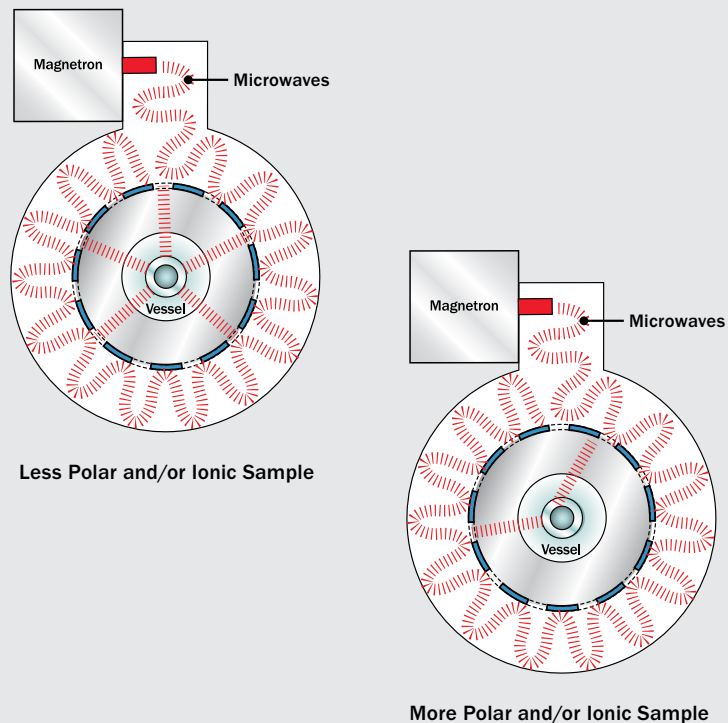

Safe Pressurized Reactions

The Discover SP patented Activent technology is the latest advance in automated pressure control and the safest way to perform pressurized reactions. The Activent pressure control system automatically relieves gaseous by products as they form during the reaction, venting safely through exhaust tubing at the back of the system. This significantly reduces vial failures, allows your reactions to reach higher temperatures, and the caps offer a secure seal, without the need for crimping tools.

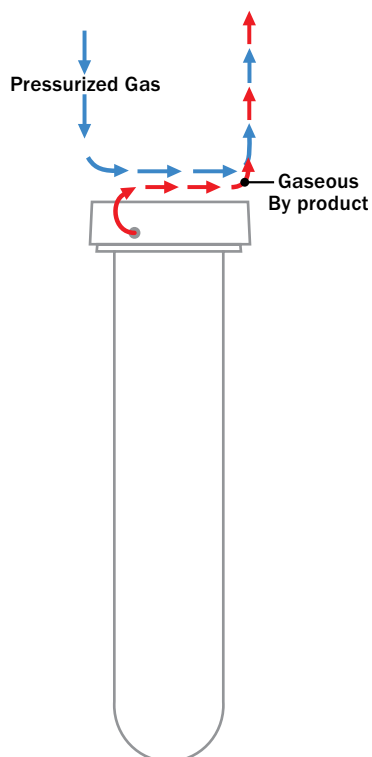

Wolff-Kishner Reduction

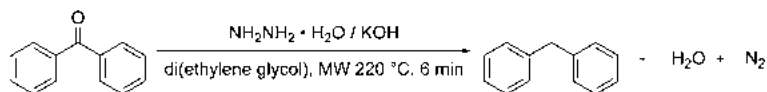

Flexible Vessel Options

Discover SP is the only single-mode microwave synthesis system capable of also performing open-vessel reactions, using standard laboratory glassware and condensers. Discover SP is compatible with reagent addition/removal and overhead stirring.

Perform either pressurized reactions in 10, 35, or 80 mL vials or non-pressurized, open-vessel reactions in standard laboratory glassware up to a 125 mL round-bottom flask. Continuous flow vessels are also available.

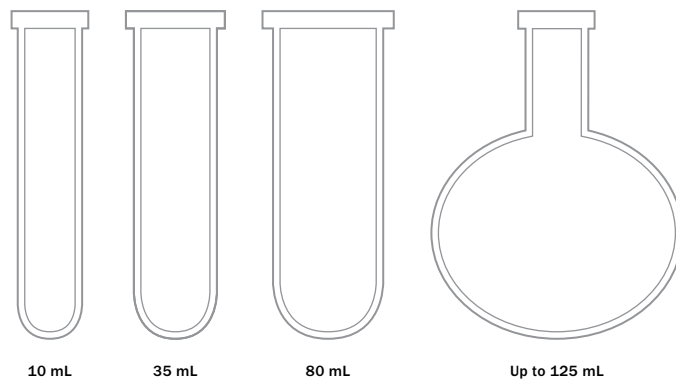

[2+2] Cyclotrimerization

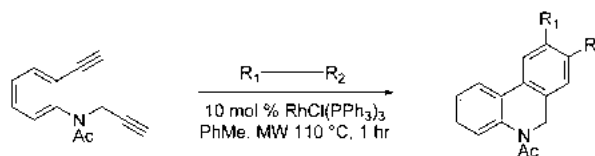

Sripada, L.; Teske, J. A.; Deiters, A. *Org. Biomol. Chem.* 2008, 6, 263 – 265.

Youg, D. D.; Deiters, A. *Angew. Chem., Int. Ed.* 2007, 9, 735 – 738



Discover SP Explorer Auto samplers

Fully automated reaction handling.

Optimize your reactions and expand the capabilities of your laboratory without expanding your lab space. Explorer auto sampler modules for the Discover SP platform provide fully automated reaction handling capabilities and are an ideal solution to support small groups of chemists as a shared resource. Run either 10 or 35 mL vessels, or a combination of both easily. Intelligent rack design allows the auto sampler to recognize the vessel type without user input, and the integrated robotics ensure that switching between 10 mL and 35 mL reaction vessels occurs seamlessly, freeing your time for other things.



Integrated Camera

Watch your reactions in real-time.

The optional integrated camera allows you to see changes occurring during your reaction. It's the perfect tool for documentation and publication support.

- Plug-n-play
- Fully adjustable
- Compact and easy-to-use



Discover Gas Addition

Use gaseous reagents with safety and ease.

The Gas Addition accessory is the only system specially designed for single-mode microwave reactions with gaseous reagents. This accessory allows you to pull a vacuum, purge the reaction vessel, and back-fill it with a gas. During the reaction, the gas source is completely shut off from the microwave, thereby ensuring your safety at all times.

Perform hydrogenations, carbonylations, or other reactions with gaseous reagents, or simply use the vessel to ensure an inert atmosphere during microwave irradiation.



The 80 mL Vessel

Scale up your synthesis.

The 80 mL vessel option (holds 50 mL) is designed for scaling up virtually any type of chemical transformation from the standard 10 and 35 mL Discover SP reaction vessels.

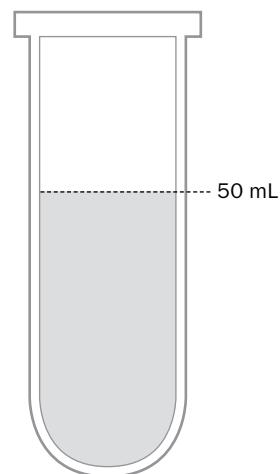

Discover CoolMate™

Accelerate reactions at sub-ambient temperatures.

The CoolMate is the only commercially available microwave accessory designed to perform reactions at sub-ambient temperatures. Reactions such as lithiation, carbohydrate synthesis, and other temperature-sensitive chemistries can now benefit from the use of microwave energy. Accelerate reactions, even at temperatures as low as -80°C .



Fiber optic temperature control

Fiber Optic Temperature Control.

The fiber optic probe provides the most precise temperature measurement available by directly measuring the temperature inside the reaction vessel. It can be used with 10 mL reaction vessels designed for this purpose, as well as with the 80 mL vessel. Other accessories, including the CoolMate and Gas Addition accessory use this type of temperature measurement.

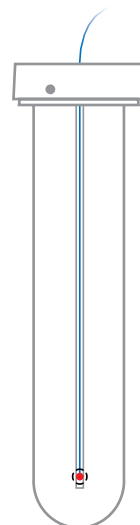



We Simplify Science

cem.com



Over 50,000 systems sold worldwide



CEM has been an ISO-certified facility since 1994



All systems serviced & supported by experts with an average of 15 years of experience



CEM invests 11% of annual revenue into R&D, the result... 11 R&D 100 awards



IQ/OQ/PQ Validation by certified CEM Technicians

United States (Headquarters)

800-726-3331
704-821-7015
Fax: 704-821-7894
info@cem.com

France

33 (01) 69 35 57 80
Fax: 33 (01) 60 19 64 91
info.fr@cem.com

Germany, Austria, Switzerland

(49) 2842-9644-0
Fax: (49) 2842-9644-11
info@cem.de

Ireland

+353 (0) 1 885 1752
Fax: +353 (0) 1 885 1601
info.ireland@cem.com

Italy

(39) 35-896224
Fax: (39) 35-891661
info.srl@cem.com

Japan

+81-3-5793-8542
Fax: +81-3-5793-8543
info@cemjapan.co.jp

United Kingdom

(44) 1280-822873
Fax: (44) 1280-822873
info.uk@cem.com